

# Installationsanleitung

CON-Line<sup>®</sup> FS 75 - 86" | Art.-Nr.: 2808

DE Installationsanleitung

GB Installation manual

FR Guide d'installation

NL Installatievoorschrift

ES Guía de instalación

SE Installationsanvisning

TR Yükleme Rehberi

RU инструкция по установке

CN 安装指南

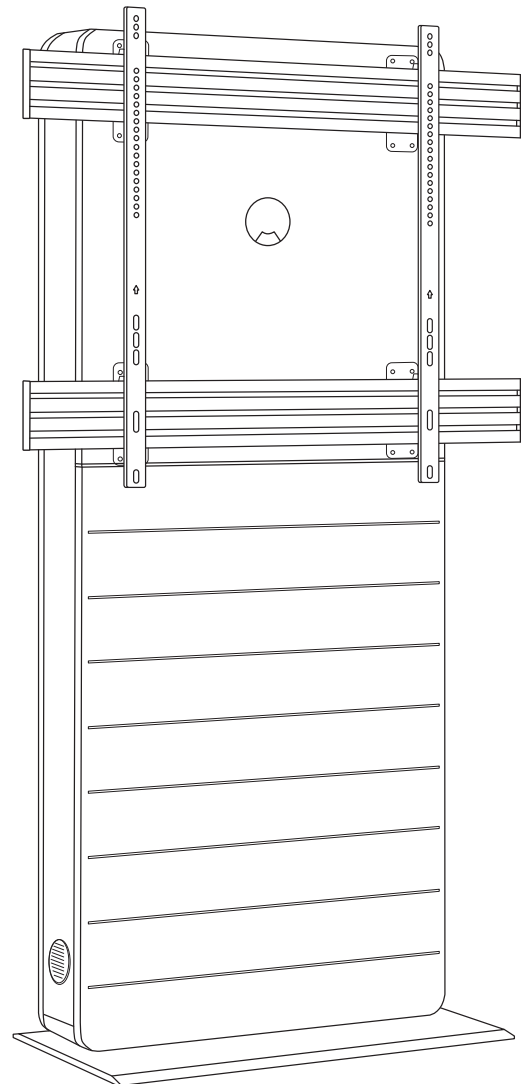

**DE**

### **Achtung!**

Technische Geräte stellen einen beträchtlichen Wert dar. Sie sollten daher bei der Installation vorsichtig mit den Komponenten umgehen und diese bei Bedarf schützen.

Auch sollte, falls nötig, der Installtionsbereich abgesichert werden. Herabfallende Teile können zu Verletzungen und Materialschäden führen.

Die im Lieferumfang enthaltenen Materialien sind unter Umständen nicht für die speziellen Gegebenheiten am Installationsort geeignet. Bitte prüfen Sie dies vorab und ersetzen Sie diese bei Bedarf durch geeignete Materialien.

Falls Sie Bezüglich der Installation des Produkts unsicher sind oder noch Fragen haben wenden Sie sich an uns oder anderes ausgebildetes Fachpersonal.

**GB**

### **Caution!**

Technical devices are of considerable value. You should therefore handle the components carefully during installation and protect them if necessary.







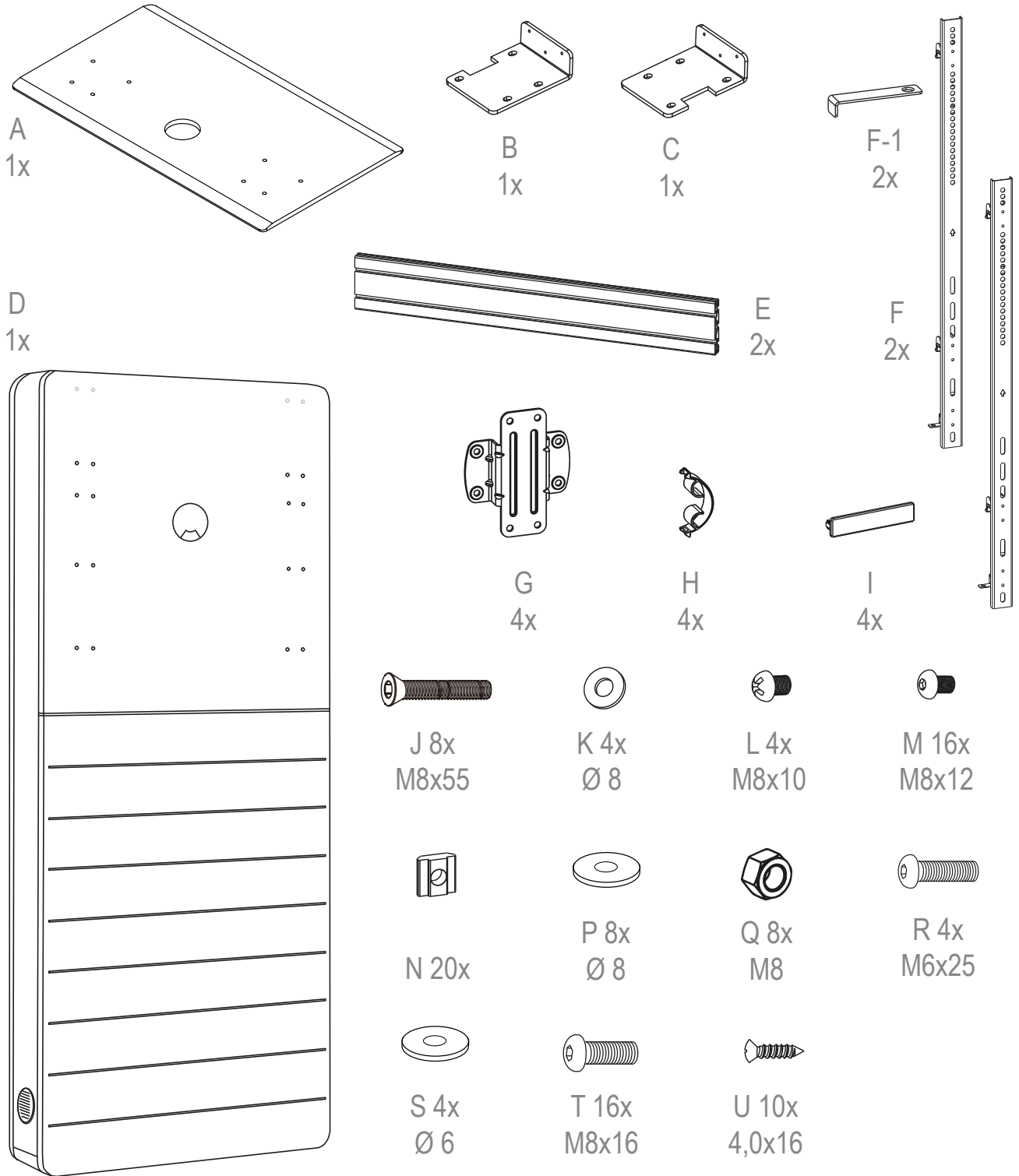

If necessary, the installation area should also be secured. Falling parts can cause injuries and material damage.

The materials included in the scope of delivery may not be suitable for the special conditions at the installation site. Please check this in advance and replace it with suitable materials if necessary.

If you are unsure about the installation of the product or have any questions, please contact us or other trained specialists.

# Lieferumfang | Scope of delivery



-   
**M-A 4x**  
 M5x14
-   
**M-B 4x**  
 M6x14
-   
**M-C 4x**  
 M6x30
-   
**M-D 4x**  
 M8x30
-   
**M-E 4x**  
 M8x50
-   
**M-F 4x**
-   
**M-G 8x**
-   
**M-H 8x**

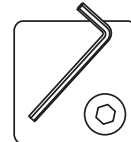
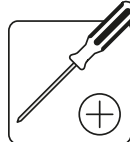
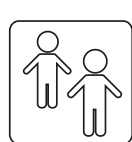

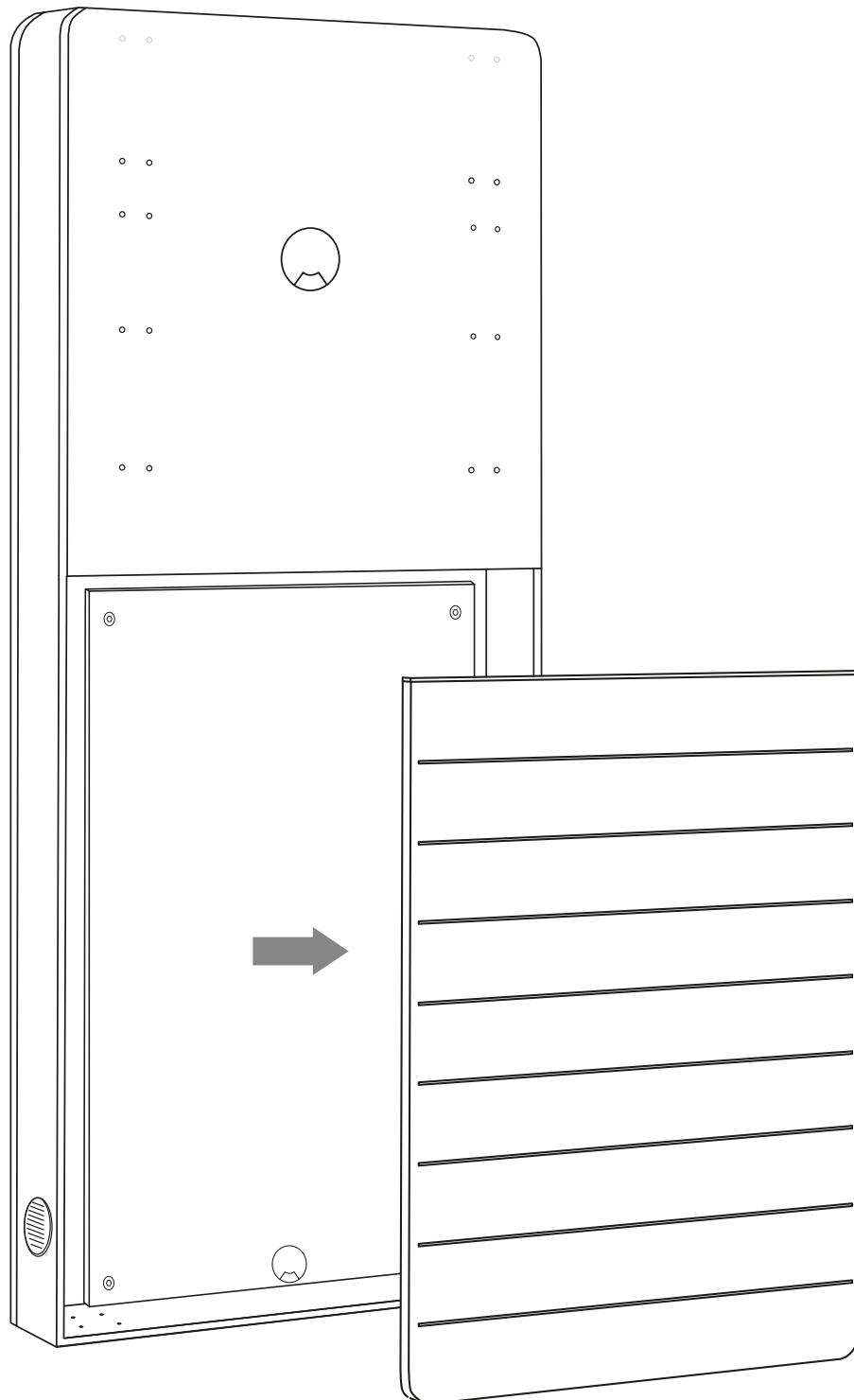

Nehmen Sie die Frontblende ab. Die Frontblende ist durch eine Magnetarretierung fixiert.  
Take off the front panel. The front panel is fixed by a magnet lock.

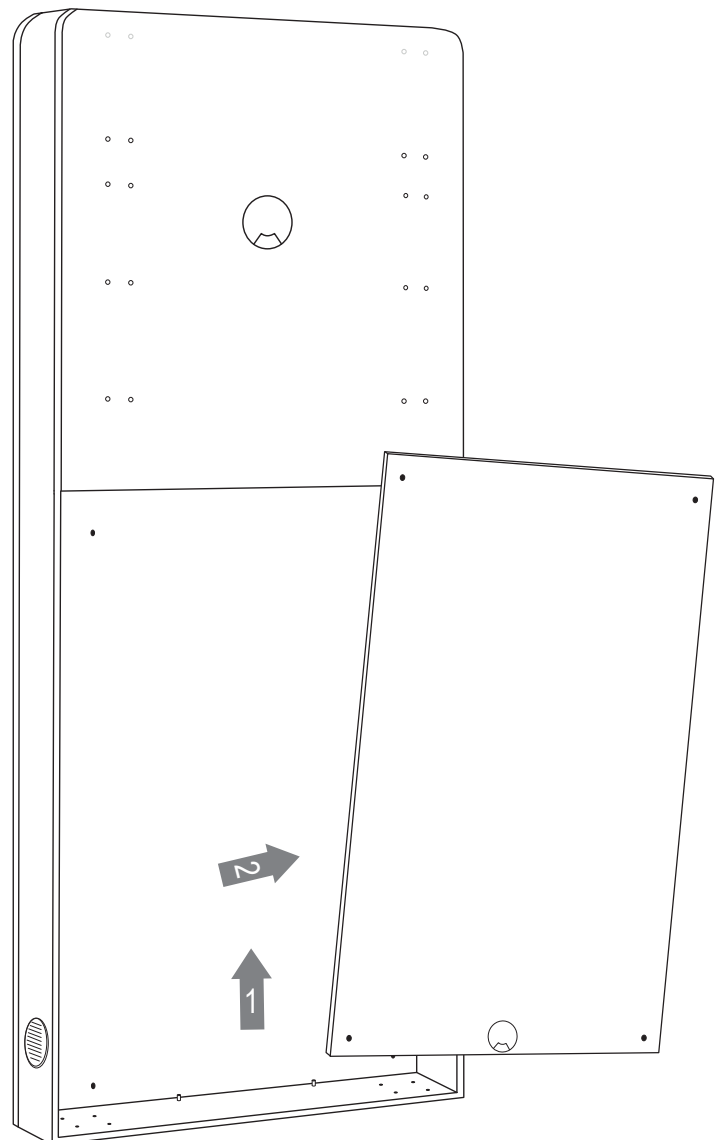
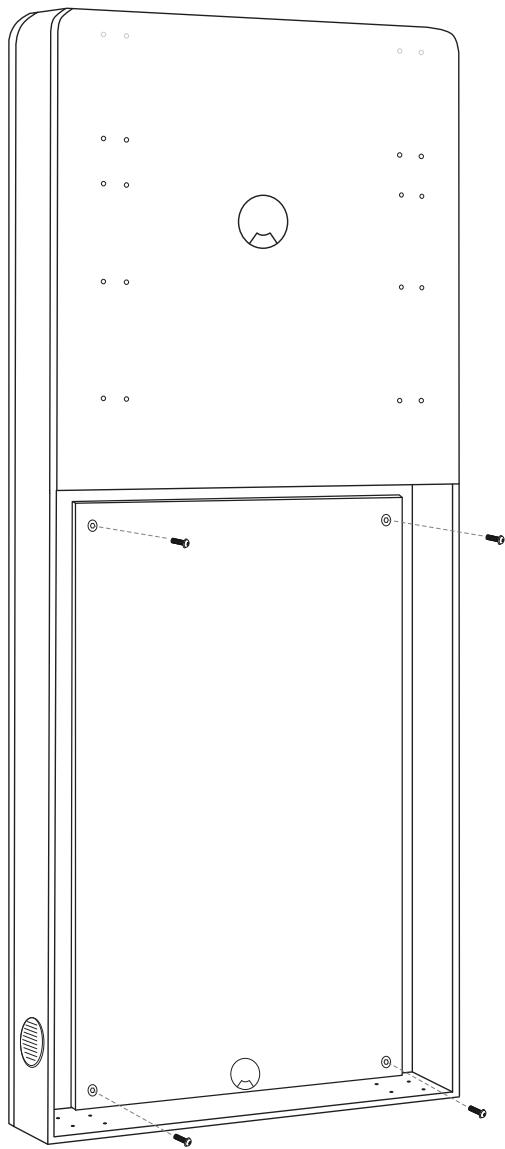
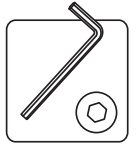

Verschraubung der Montageplatte von der Rückwand lösen.  
Loosen the screw connection of the mounting plate from the rear panel.

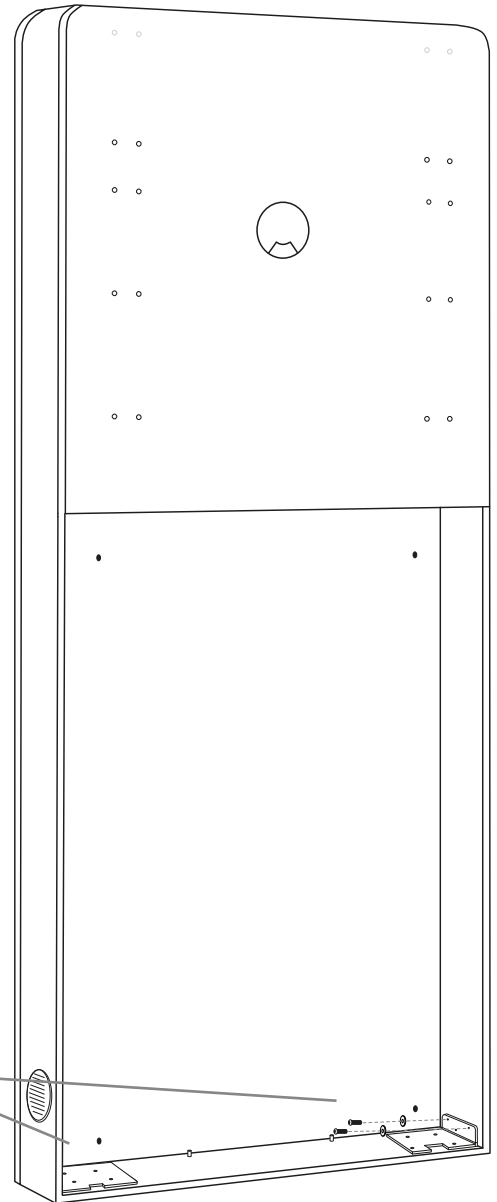
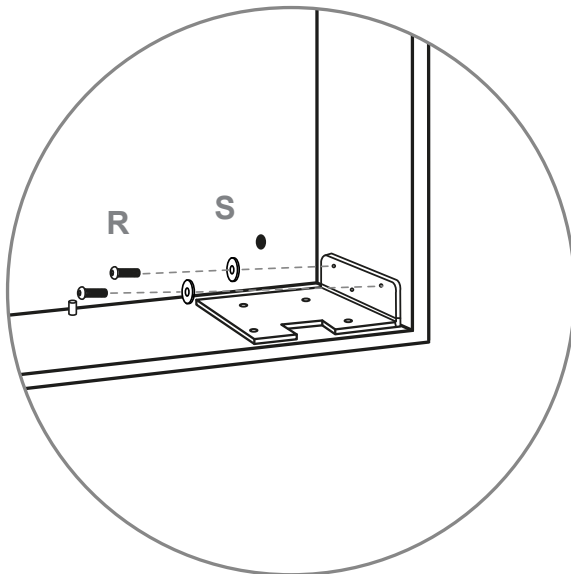
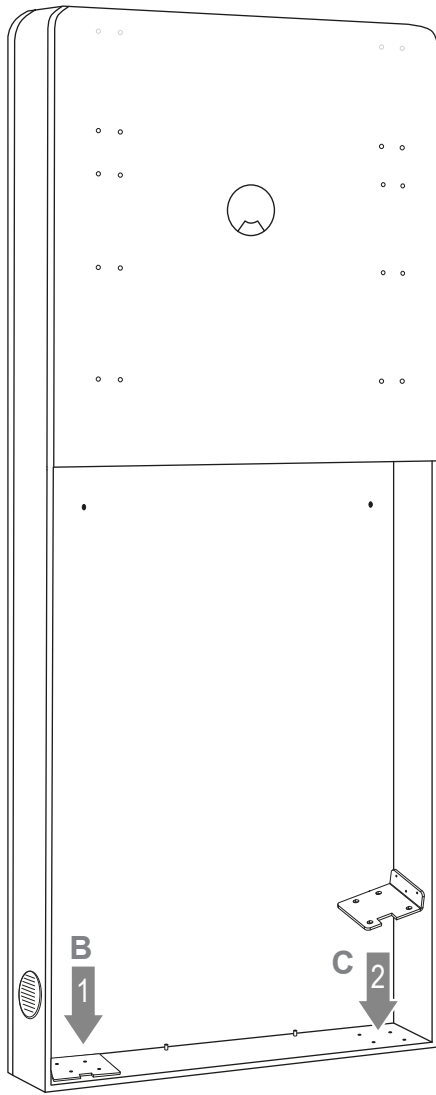

Setzen Sie die Winkel B und C in den Korpus und verschrauben Sie diese in die Seite des Korpus.  
Place brackets B and C in the corpus and screw them into the side wall.

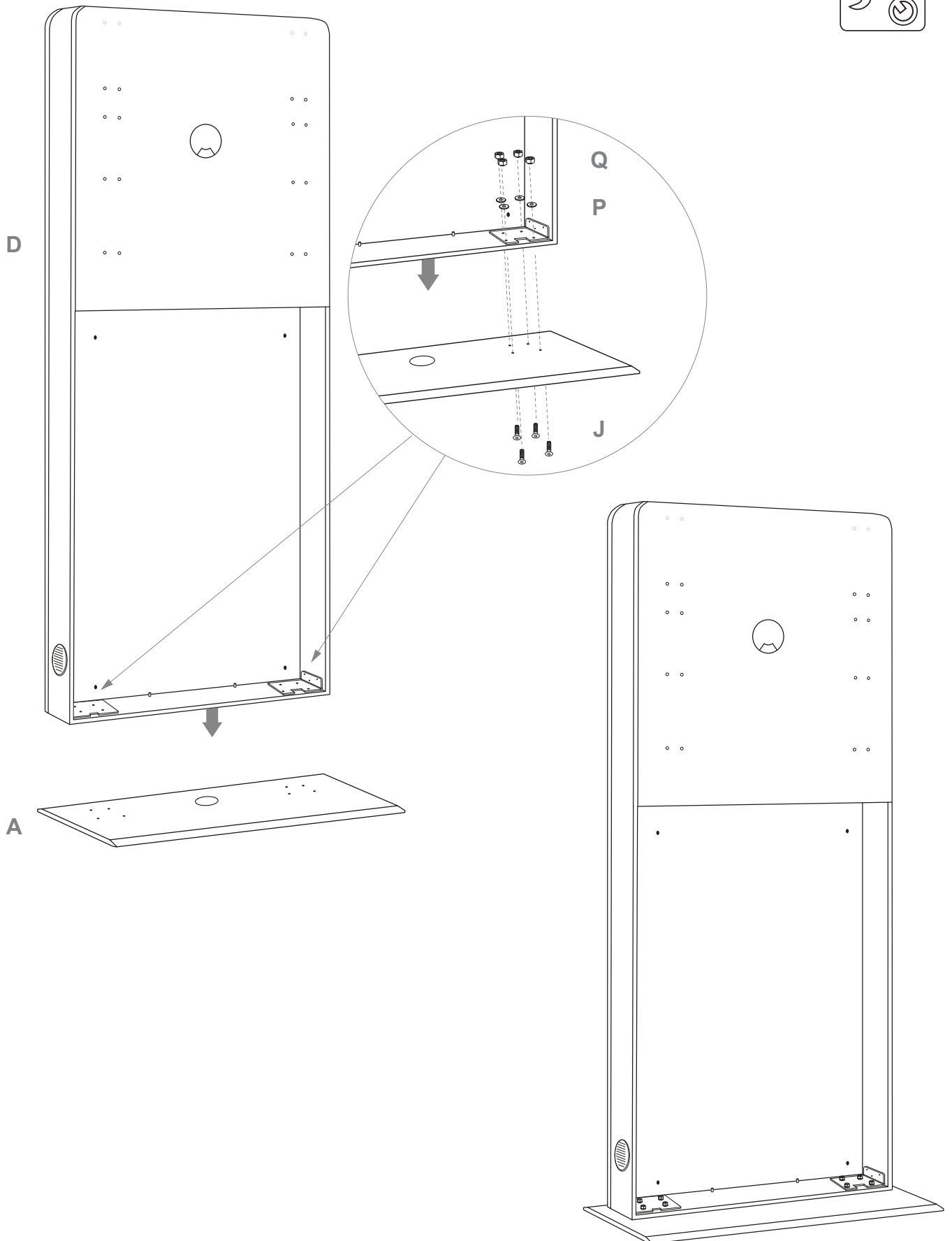

Legen Sie den Korpus auf den Rückseite und fixieren Sie die Bodenplatte mittels Schrauben, Scheiben und Muttern.

Stellen Sie das Stele danach wieder auf.

Lay the corpus on its back and fix the base plate with screws, washers and nuts. Then set the totem up again.

5

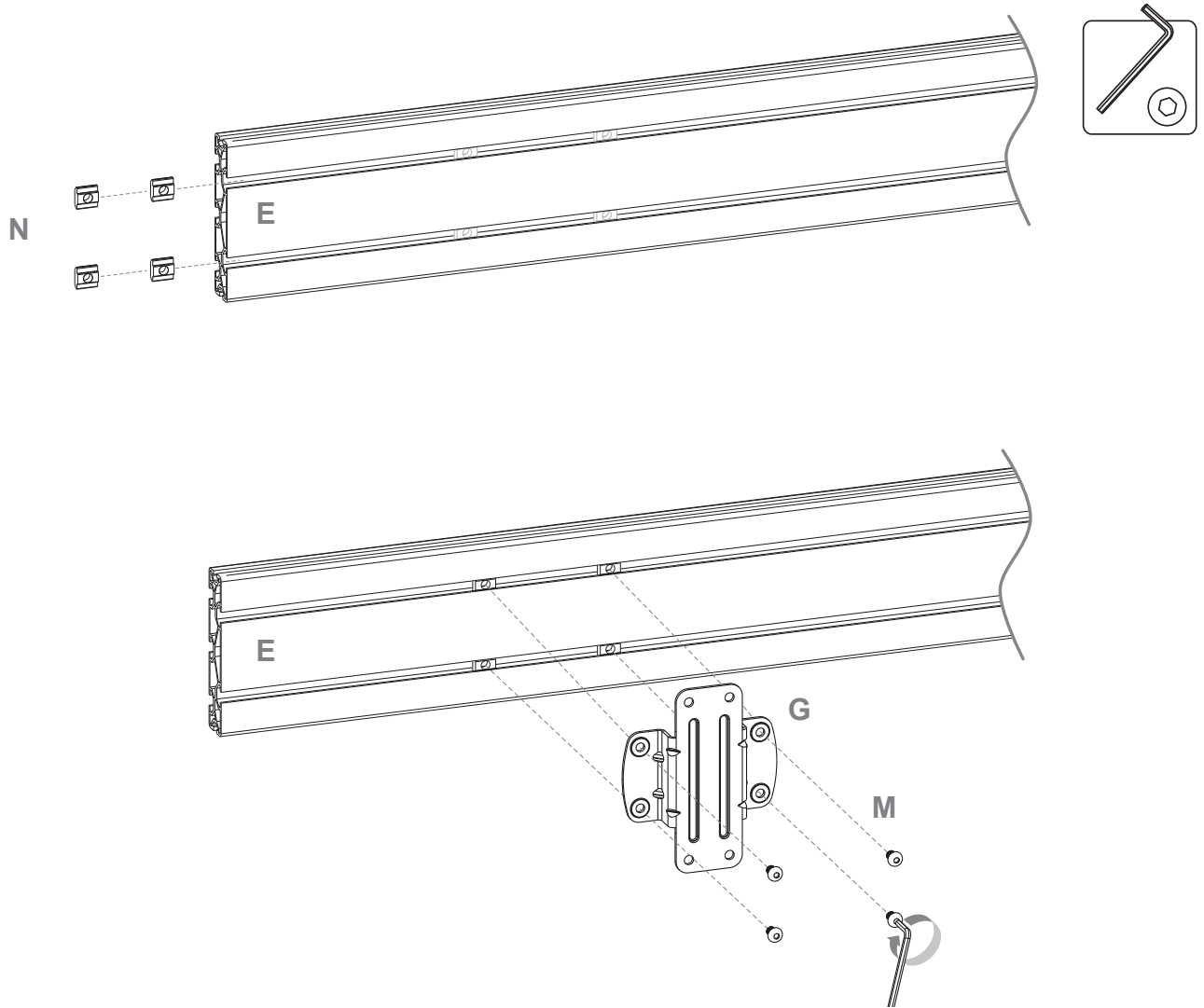

Ziehen Sie die Schrauben noch nicht ganz fest, damit ein nachjustieren der Position möglich ist.  
Do not tighten the screws completely so that the position can be readjusted.

6

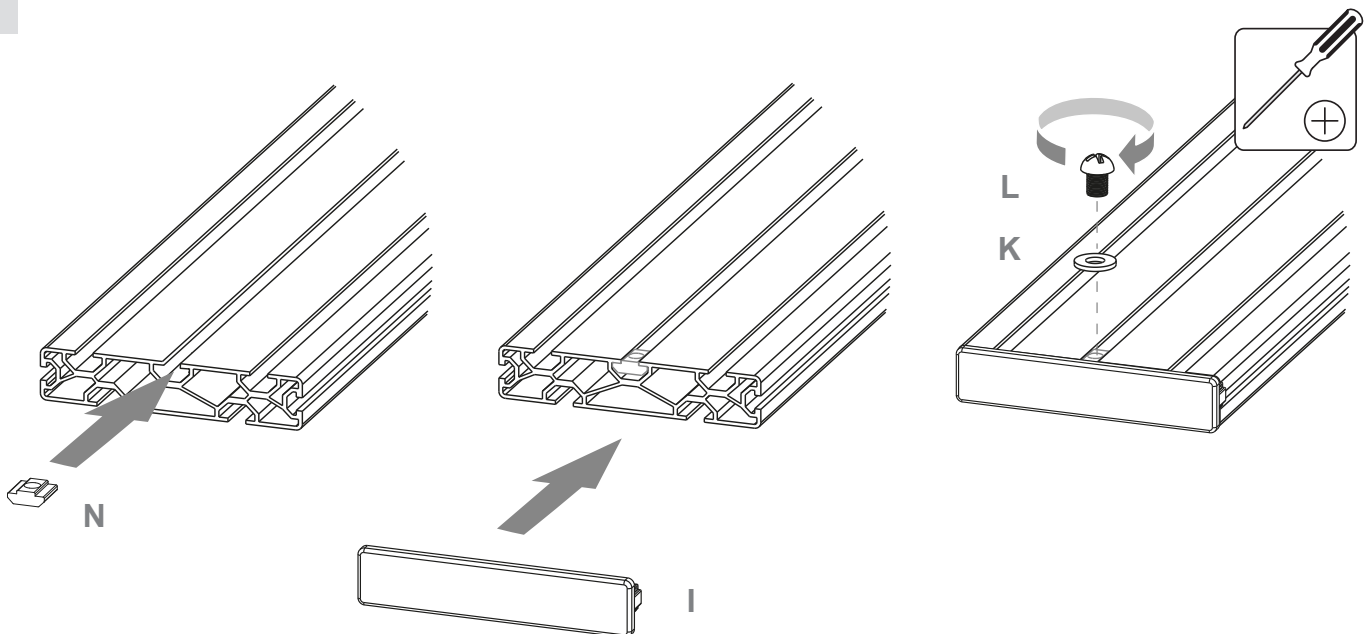

Die Nutensteine in die Schiene schieben, Kappen aufsetzen und beides festschrauben. Auf der anderen Seite ebenso.  
Slide the slot nuts into the rail, put on the caps and screw both tight. On the other side as well.



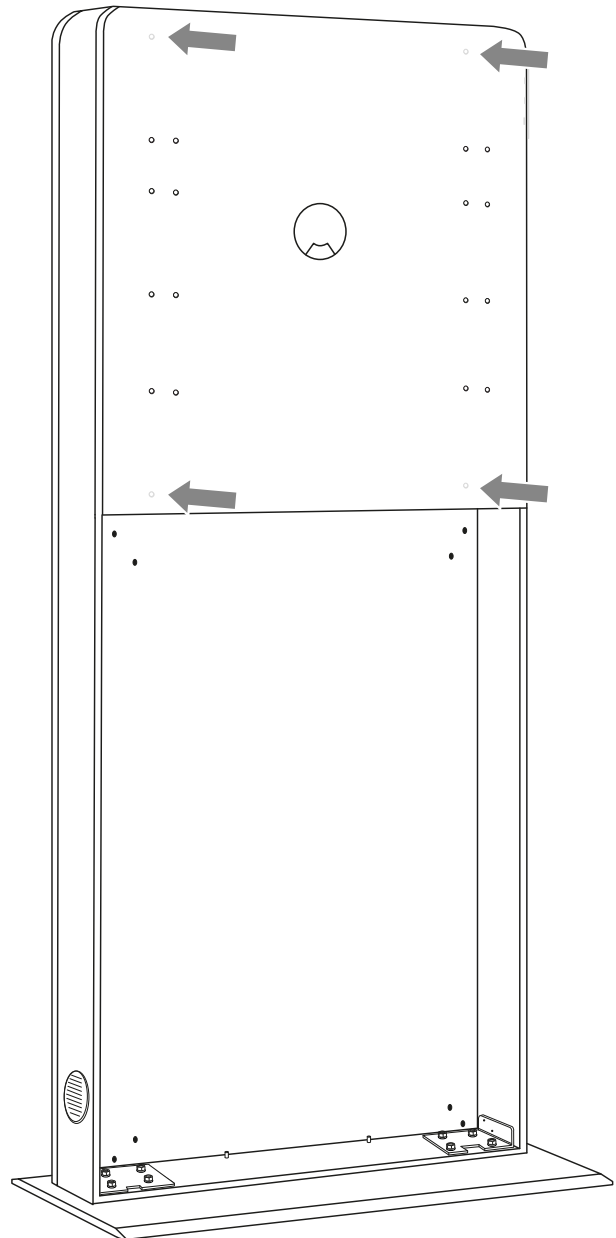
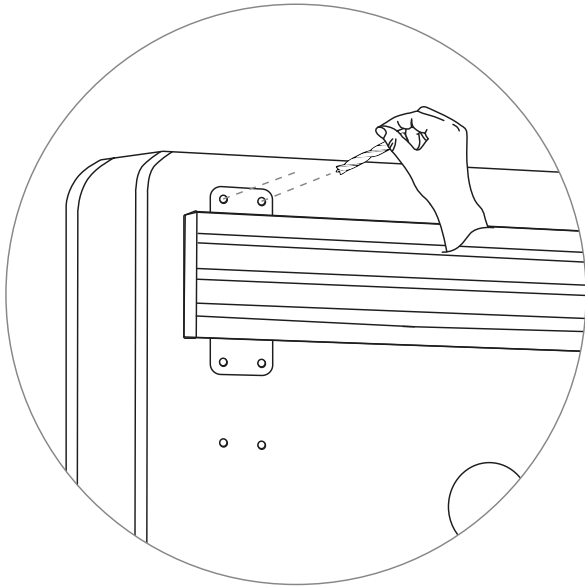

Zur Montage in der obersten oder untersten Montageposition, müssen die verdeckten Verschraubungspunkte, mit zum Beispiel einem 8er Holzbohrer, freigelegt werden. Nutzen Sie hierfür die Befestigungsadapter als Schablone gemäß Abbildung.

For mounting in the top or bottom mounting position, the concealed screwing points can be uncovered, for example with a size 8 wood drill bit. To do this, use the fastening adapter as a template as shown in the illustration.

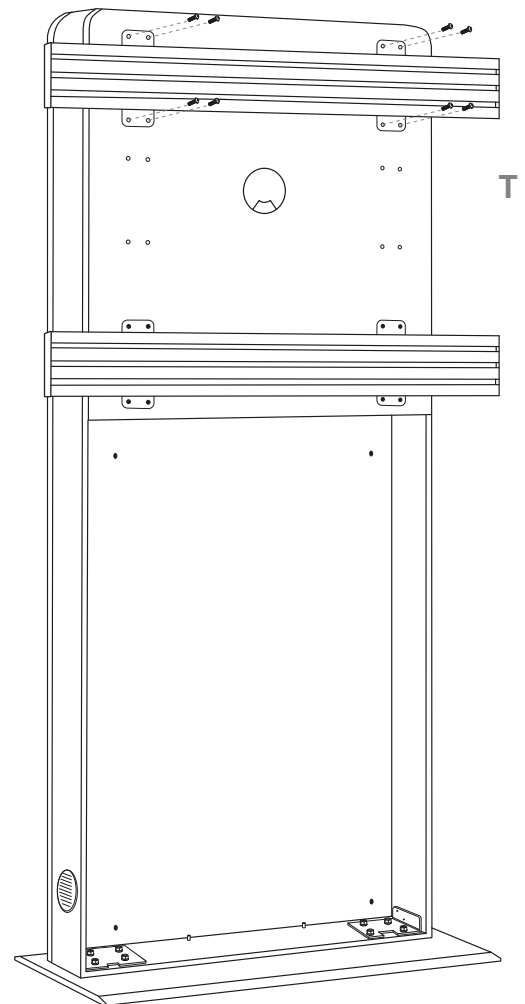
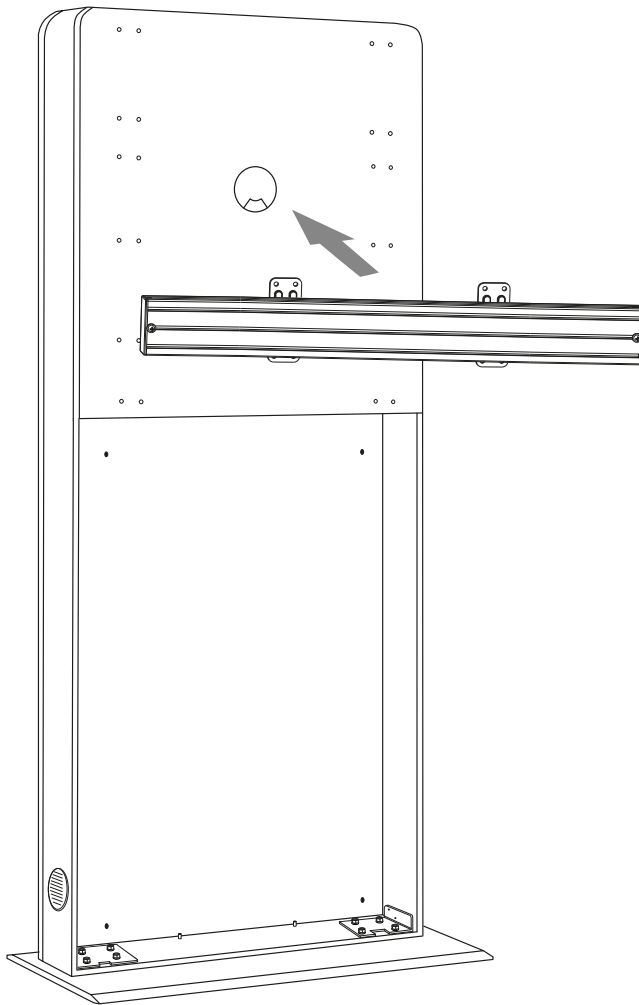
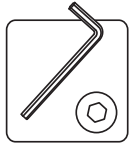

Richten Sie die Schienen mittig aus und ziehen Sie die rückseitigen Schrauben jetzt richtig fest.

Align the rails centred and tighten the screws on the back properly now.



oben | top

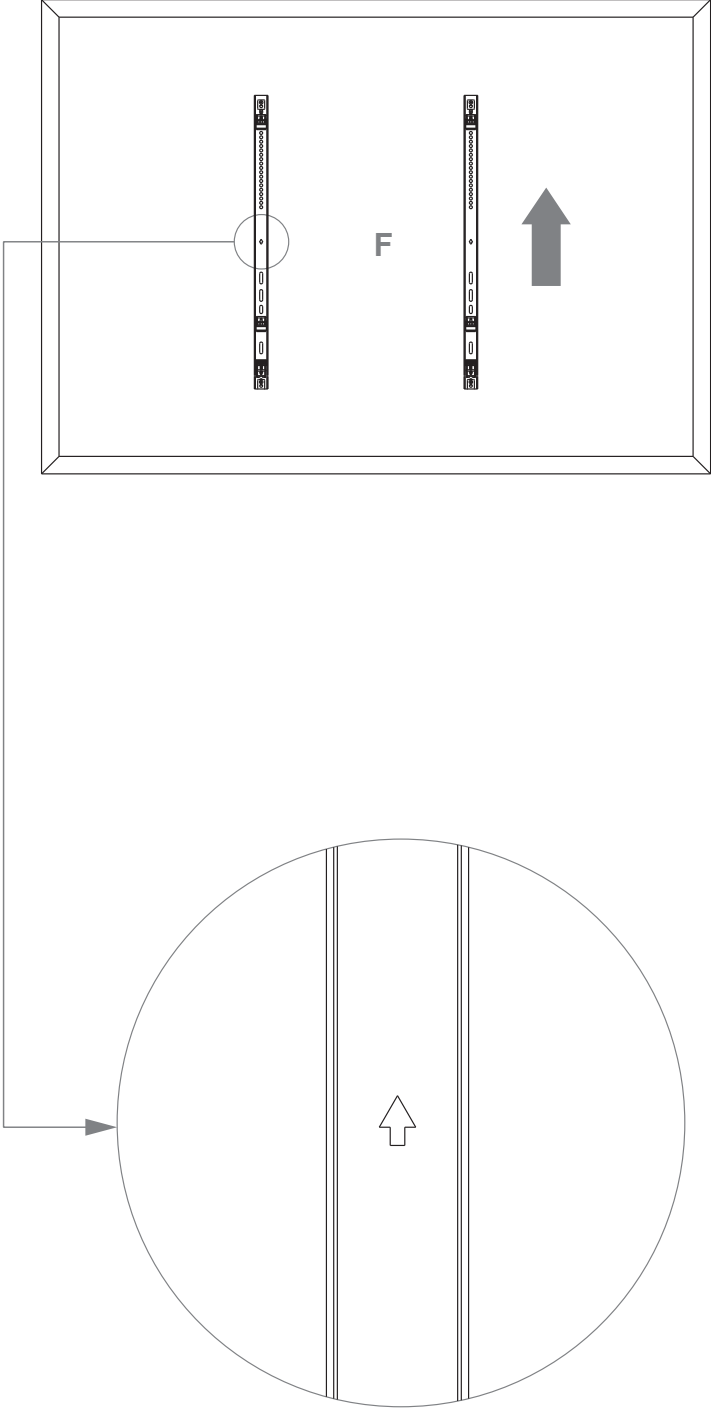

10a

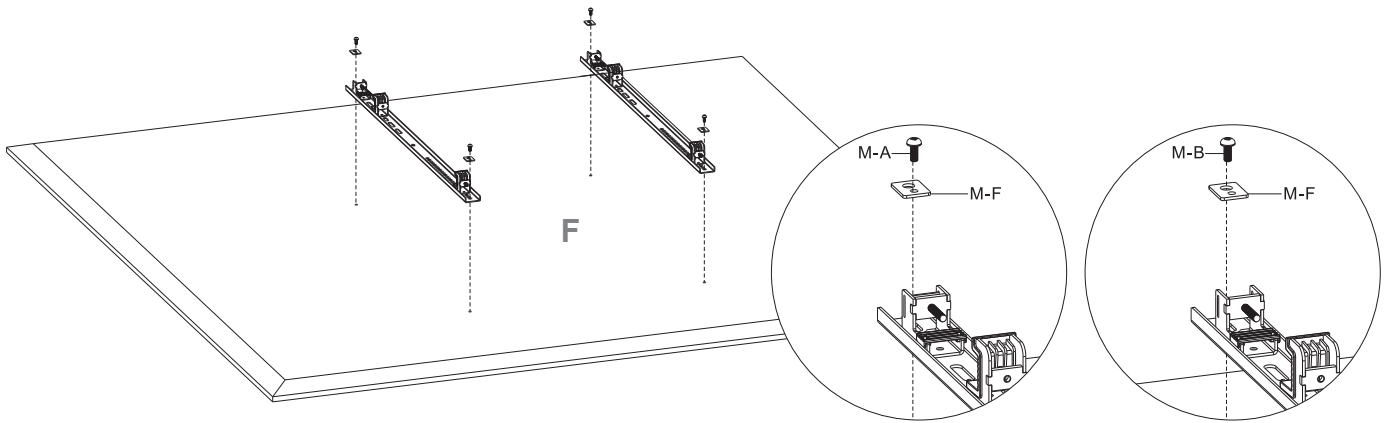
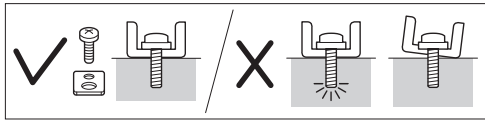

10b

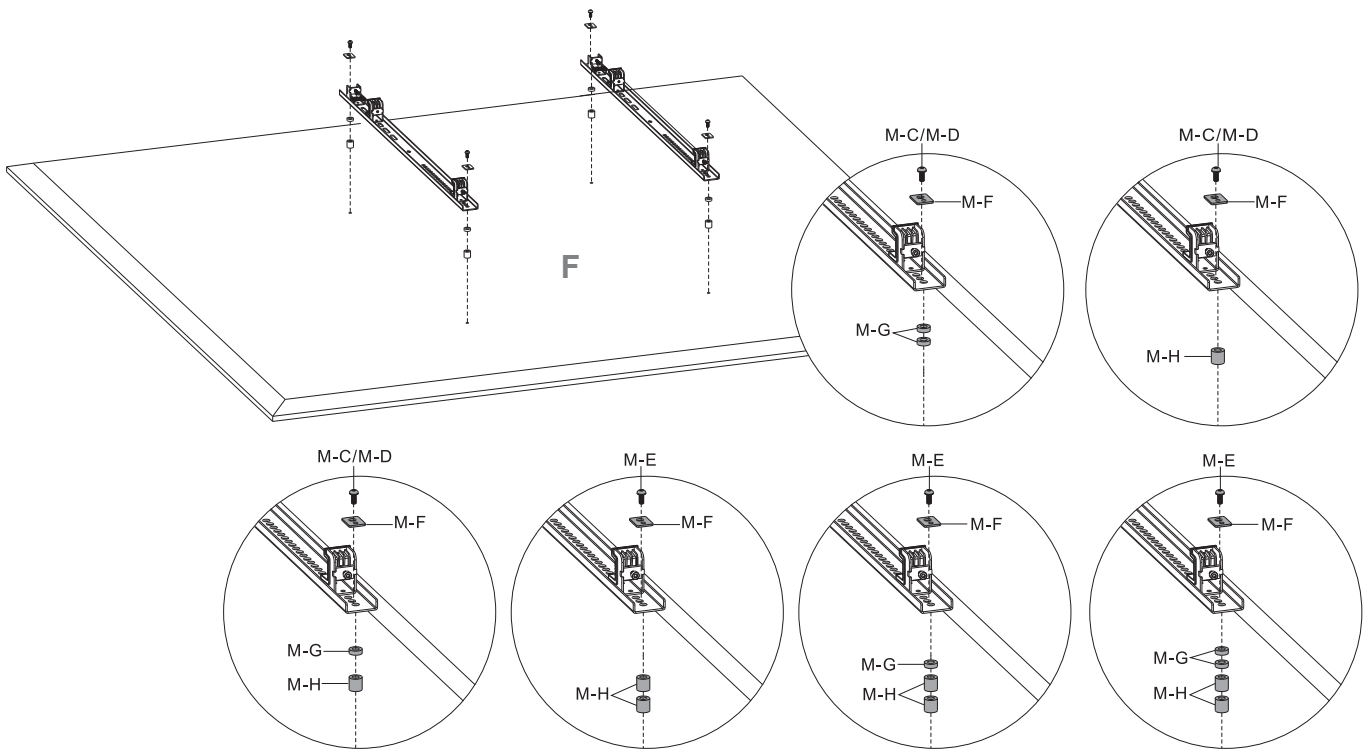
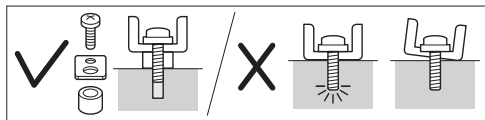

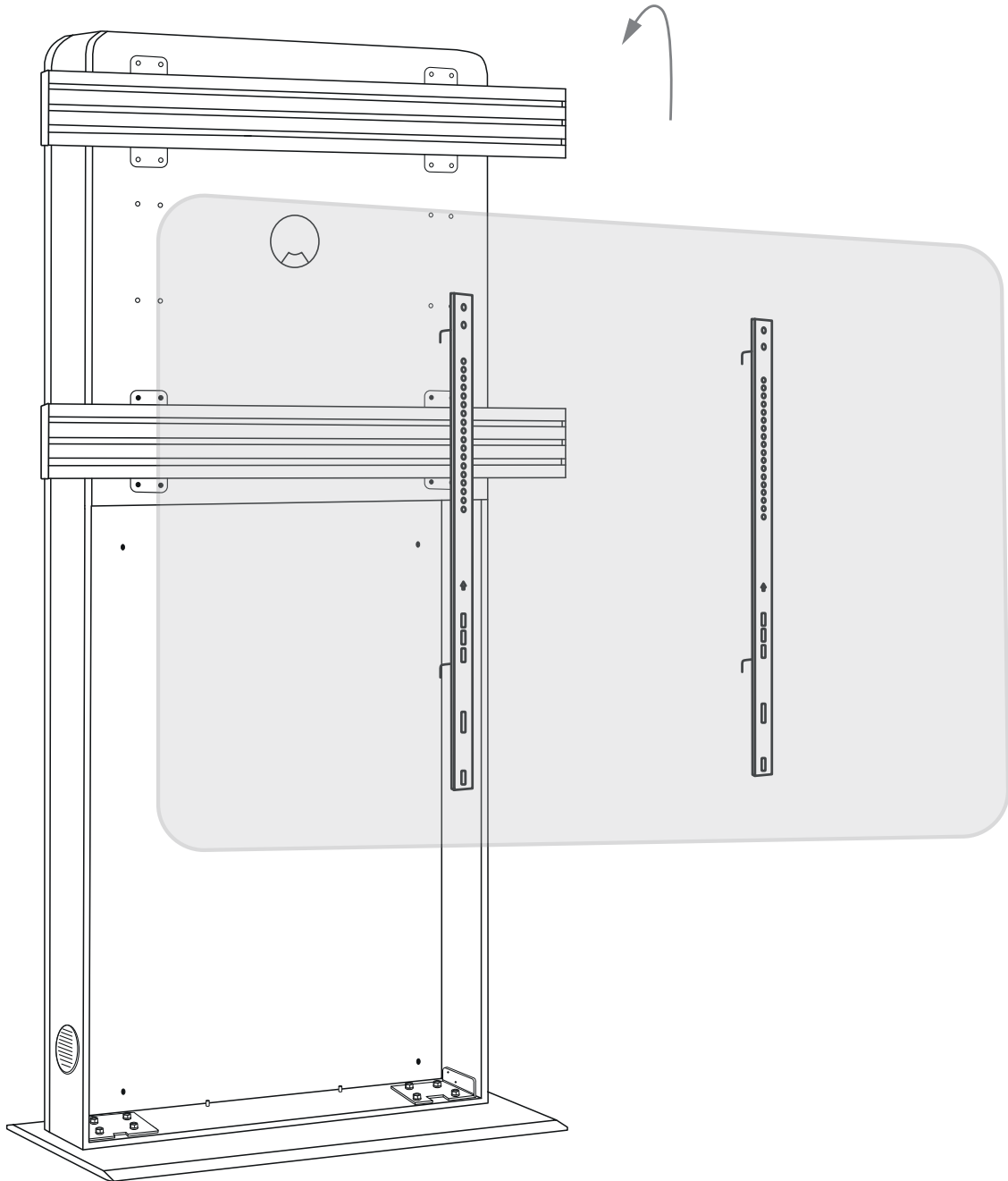

Hängen Sie den Bildschirm in die Halterung ein. | Attach the screen to the bracket.

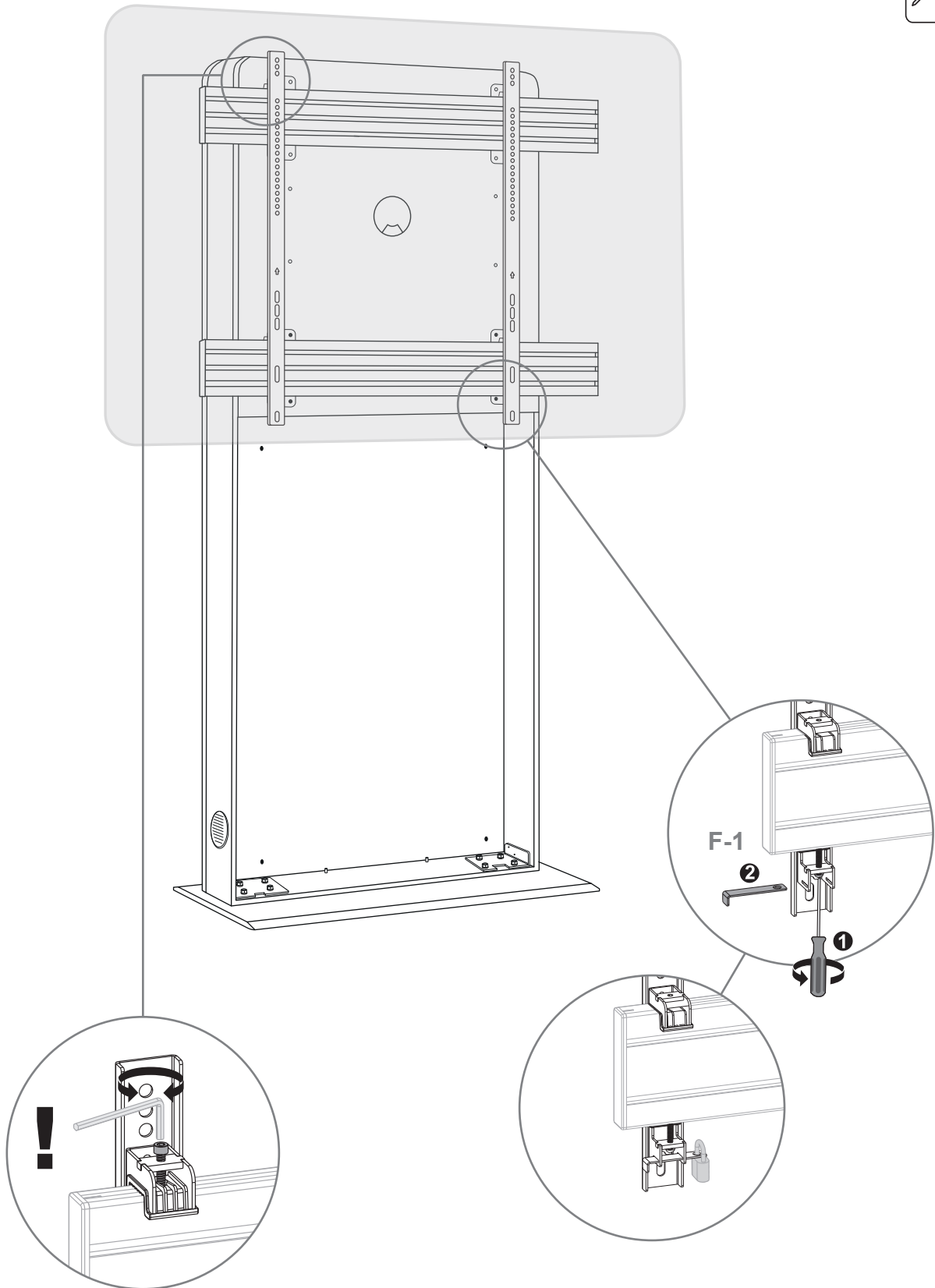

Ziehen Sie nach dem Ausrichten, die Sicherheitsschrauben fest. | After aligning, tighten the security screws.

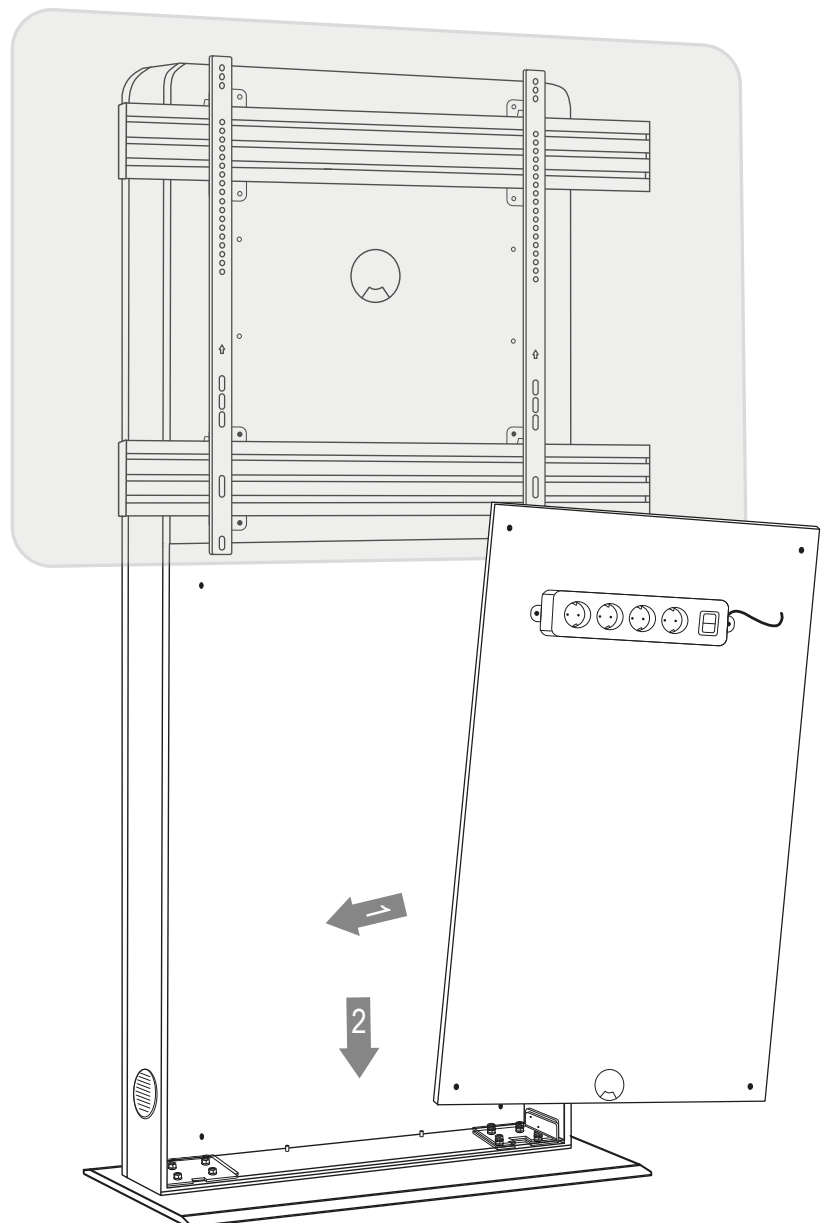
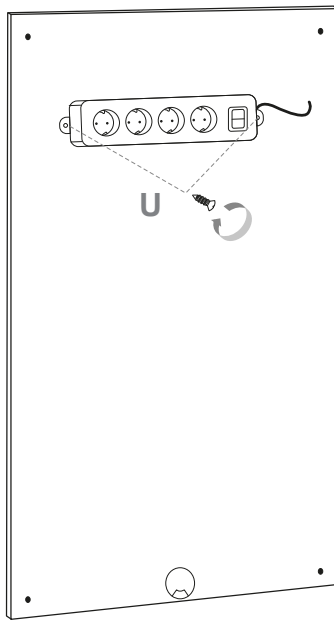

Positionieren Sie das benötigte AV-Zubehör frei, nach Ihren Wünschen, auf der Montageplatte.

Position the required AV accessories freely, according to your wishes, on the mounting plate.

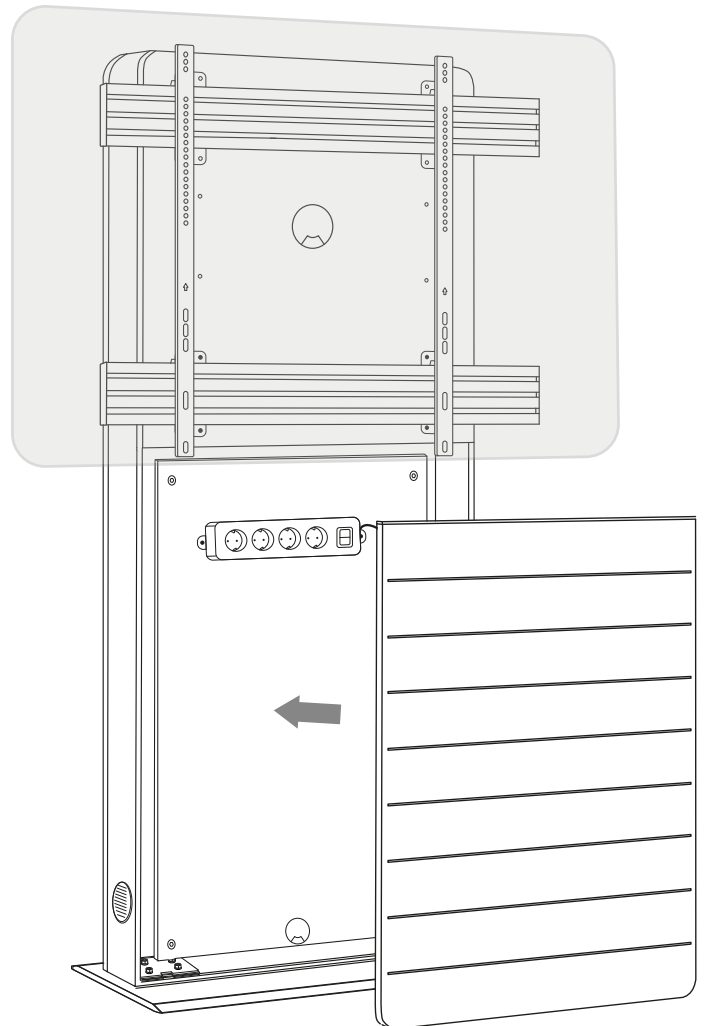
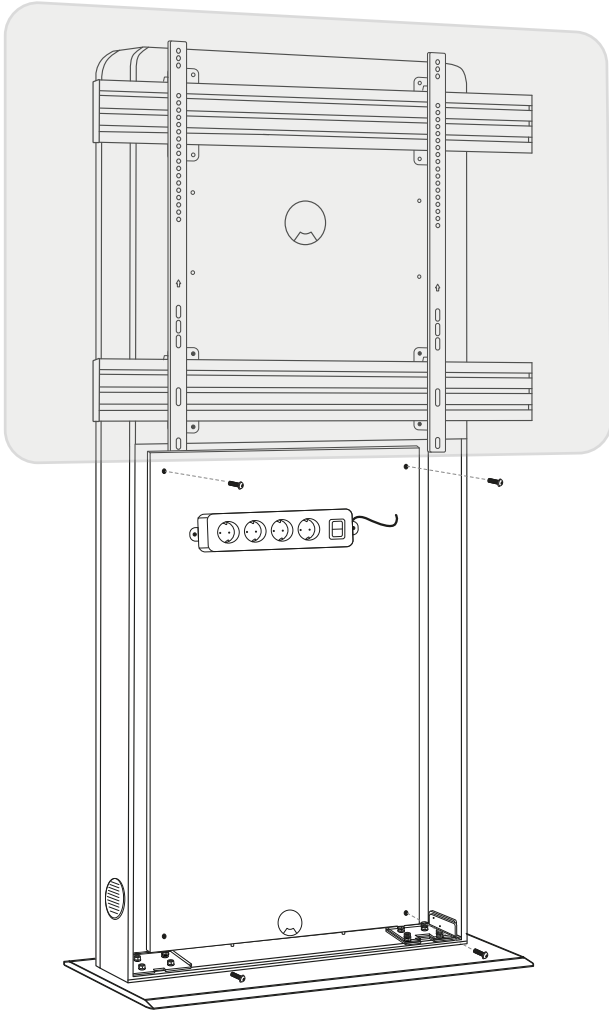

Verschrauben Sie die Montageplatte wieder an der Rückwand. Abschließend wird die Frontblende wieder vorne am Korpus befestigt. Die Frontblende ist durch eine Magnetarretierung fixiert.

Screw the mounting plate back to the rear wall. Finally, the front panel is attached to the front of the corpus again. The front panel is fixed by a magnet lock.



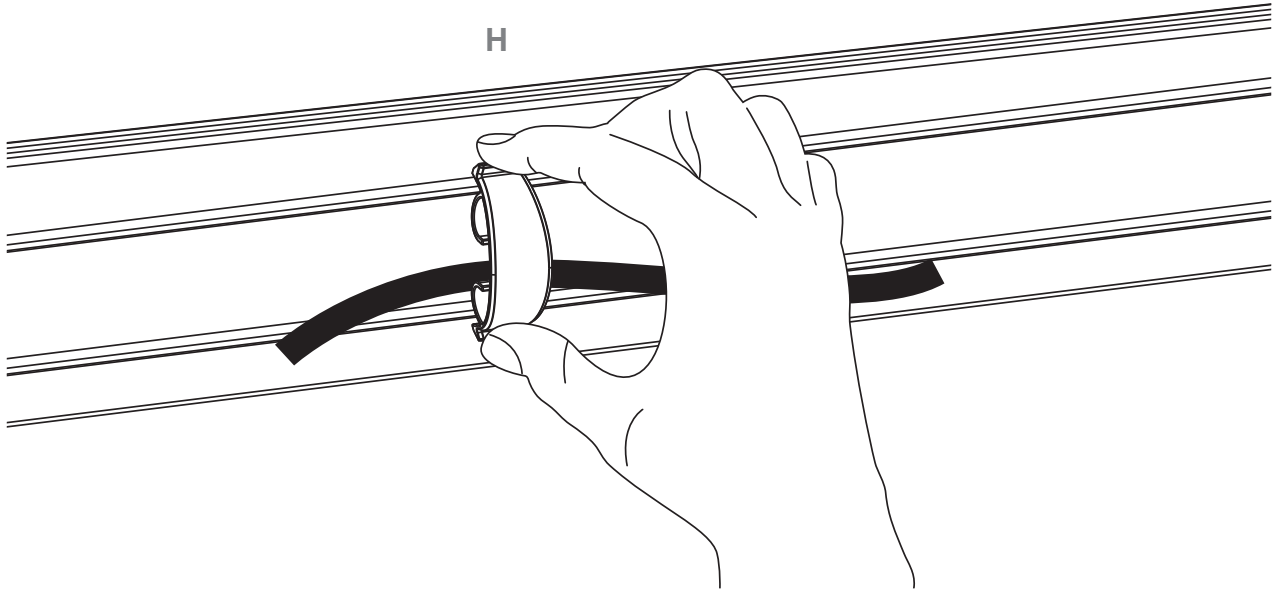

## Abmessungen | Dimensions

